



- Compact, economical design allows the autoMAP100-Mini to fit in processing facilities where space is at a premium
- Performs all of the same processes as the larger sized models
- Perfect for lower-output facilities working on a budget
- Full automation features and online diagnostic access



## APACK autoMAP100 and autoMAP200 Series

APACK autoMAP100 and autoMAP200 series machines provide fully automatic tray sealing and MAP (Modified Atmosphere Packaging) solutions for food production facilities of all different sizes and output volumes.

All of the machines in the APACK autoMAP100 and autoMAP200 series are designed to be customizable, dependable, efficient, and easy to use. Decades of research, development, and industry experience allow APACK to offer you the perfect MAP solution to fit your facility's unique requirements.

## All-in-One, Fully-Automated MAP Solution

Each of the autoMAP100 and autoMAP200 series machines has the ability to carry out fully-automated MAP process and continuous operation.

### Efficiency and Ease of Use

- Simple, intuitive touch-screen panel makes for fast and easy operation and reduces user error
- Multi-program memory allows for quick transition between different packaging types
- Maintain a safe, sterile food processing environment: stainless steel body, easily removable panels, and hygienically designed conveyor belts and moving parts make frequent cleaning easier

### Versatility

- All operation parameters can be adjusted to various tray and film sizes
- Vacuum packing function for easy hermetic sealing of liquids, sauces, dressings, and hot-filled products
- Many customization features are available to fit your facility's specific needs

### Dependability

- PLC control circuits constantly monitor operation to protect equipment against possible faults, misuse, or malfunction
- Invicta's industry-leading customer service and support means you'll avoid costly interruptions in production
- Designed and manufactured by APACK - over 20 years at the leading edge of food packaging
- Designed to operate 24/7 under normal conditions with no interruptions

### Different Models to Fit Your Needs

- The APACK autoMAP100 and autoMAP200 series include four different models, so you can choose one that addresses your needs perfectly.

To learn more about our products visit: [www.invictafortis.com](http://www.invictafortis.com)

18 Blackjack Rd. STE 101 Fredericksburg, VA 22405 • 540.300.3434 • [hello@invictafortis.com](mailto:hello@invictafortis.com)

## APACK autoMAP100-Mini TECHNICAL DATA

Vacuum Pump	105 - 205 m <sup>3</sup> /h
Compressed Air Consumption	90 psi (6 bar) constant and dry
Gas Pressure	30 - 90 psi / 2 - 6 bar
Control Panel	Touchscreen
Dimensions (WxLxH)	990 x 3,350 x 2,050 mm
Loading Area Length	800 mm
Weight	600 - 800 kg
Max Film Width	400 mm
Max Cut-off Length	460 mm

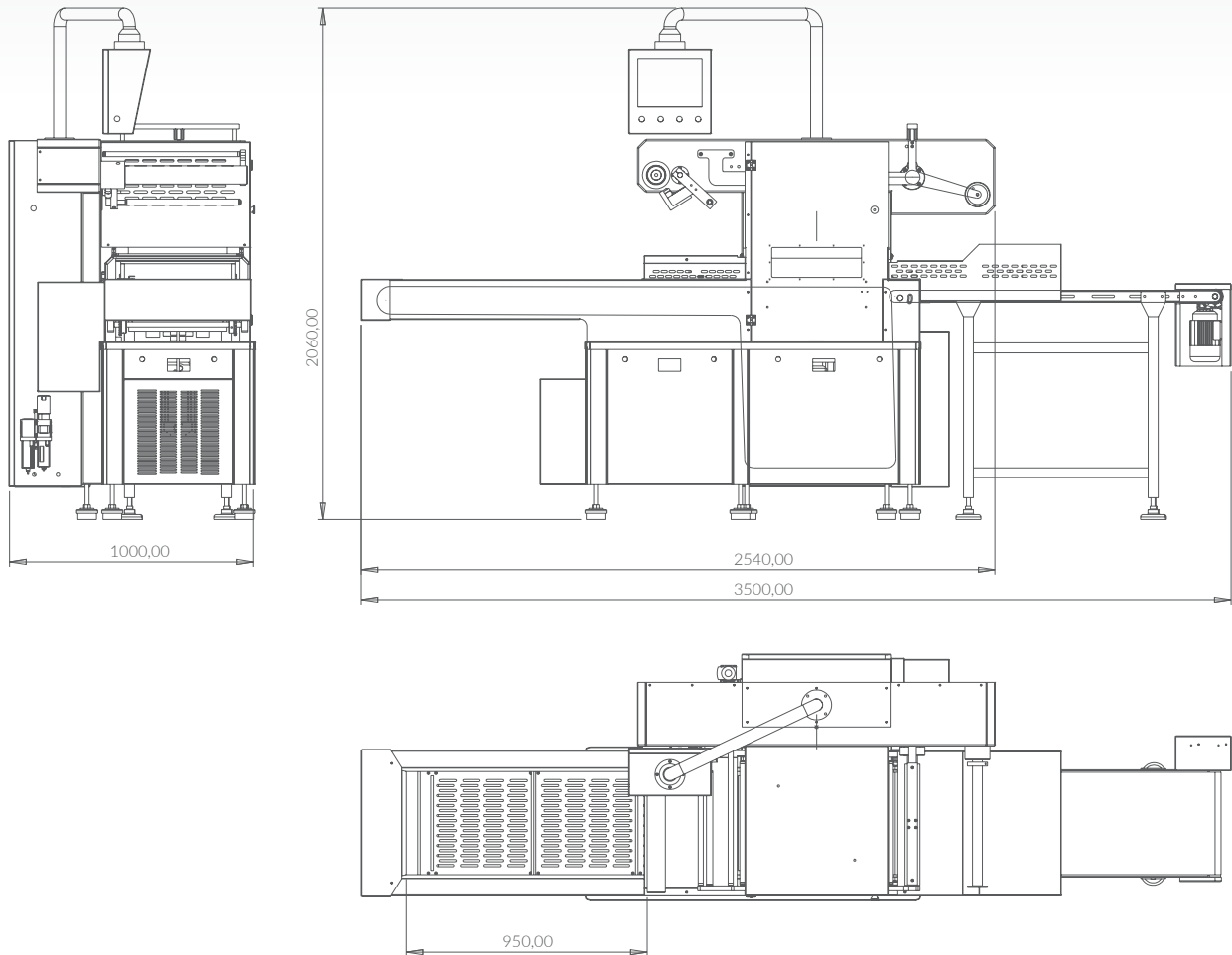

To learn more about our products visit: [www.invictafortis.com](http://www.invictafortis.com)

18 Blackjack Rd. STE 101 Fredericksburg, VA 22405 • 540.300.3434 • hello@invictafortis.com