



MAP25



MAP25-X

The APACK MAP25 Tray Sealing Machine is ideal for small and medium-sized food producers.



Designed and built by APACK, one of the most trusted names in the industry, our machines can help you achieve increased production while maintaining the highest standards of quality, and with fewer hassles.

Ease of Use

- Intuitive touch screen interface makes operations simple and reduces user error
- Multi-program memory allows operators to quickly and easily switch between different products
- Stainless steel structure is designed to be easy to regularly clean and sanitize

Versatility

- Quick-change molds and tray sealing tools allow MAP25 to be used with a wide variety of different tray sizes and configurations
- Compact design fits easily into virtually any food production facility
- No adjustments necessary to settings if MAP25 needs to be relocated to different area of facility

Low Operation Cost

- Only one operator required for most models.

Dependability

- Our machines are constructed from the highest quality electrical and mechanical components
- Invicta's industry-leading customer service and support means you'll avoid costly interruptions in production
- Designed and manufactured by APACK-over 20 years at the leading edge of food packaging
- Designed to operate 24/7 under normal conditions with no interruptions

To learn more about our products visit: www.invictafortis.com

18 Blackjack Rd. STE 101 Fredericksburg, VA 22405 • 540.300.3434 • hello@invictafortis.com

5 Models to Suit Your Company's Needs

- APACK MAP25 (Base Model): Standard components, supports different tray and film types.
- APACK MAP25-E (Extended): Optimized for larger tray sizes, this model is built to accommodate different dimensions based on the customer's specific requirements.
- APACK MAP25-DS (Double Station): Provides double production capacity for high-output facilities.
- APACK MAP25-Skin: Skin packaging forms the transparent top film to the contours of the food product. The MAP25-Skin can be customized to fit packaging tray heights from 10mm up to 35mm.
- APACK MAP25-X: Designed to accommodate larger, heavier trays with conveyors on each side.

APACK MAP25 TECHNICAL DATA

Vacuum Pump	35cfm / 60m3/h
Air Pressure	90 psi / 6 bar (dry)
Compressed Air Consumption	0.25 cf/cycle, 1cfm / 7 nl/cycle, 30 nl/min
Gas Pressure	30 - 90 psi / 2 - 6 bar
Control Panel	Touch screen - 24 lines
Dimensions (WxLxH)	30.70" x 52.16" x 69.30" / 780 mm x 1,325 mm x 1,760 mm
Weight	995 lbs / 450 kg
Film Width	Max. 19.68" / 500 mm
Capacity	2 - 6 cycle/min

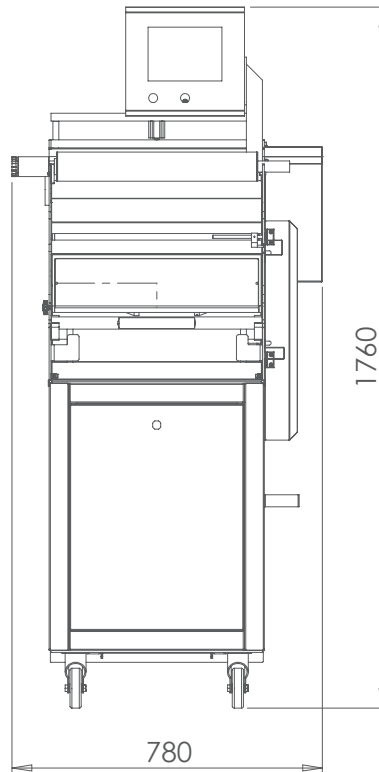
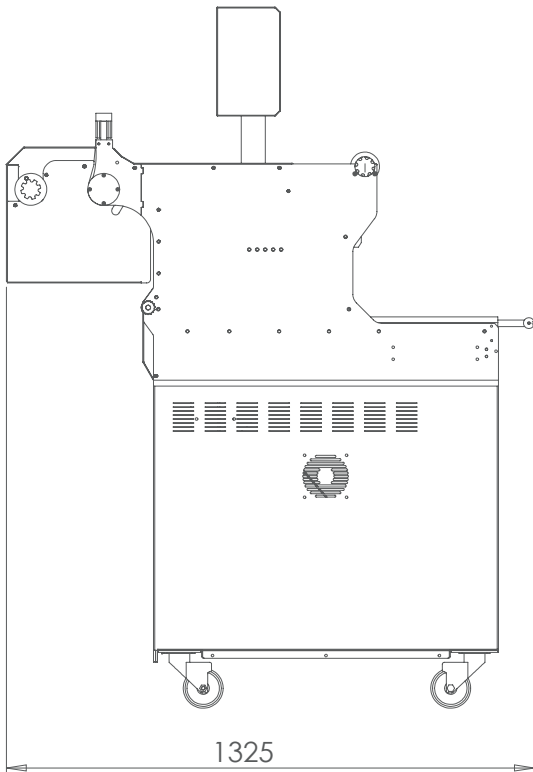

To learn more about our products visit: www.invictafortis.com

18 Blackjack Rd. STE 101 Fredericksburg, VA 22405 • 540.300.3434 • hello@invictafortis.com